

Wood acoustics are designed to seamlessly cover larger surface areas simply, beautifully, and most importantly, functionally. Transforming simple walls and ceilings into stunning ambient or accent additions, that also solve a space's sound challenge, has never been easier. Other wood systems require additional acoustic materials, large holes or gaps, and sub-walls. Trava and Aoudi are different, they are the acoustic panel, no extra work or products required. And thanks to our close partnership with Jacaranda Sanfoot, our wood can be matched and sequenced across millwork, MDF, and direct to drywall veneer.

---

## Say bye-bye to fiberboard.

Welcome to the next generation of wood panels. The noise canceling acoustic core adds function, updated materials are eco-friendly and dramatically reduce weight, and installation is simpler. Only the great look of the old panels remains.

# Specifications

<b>Product Name</b>	Trava Wall
<b>Lead Time</b>	10 weeks
<b>Content</b>	Premium wood veneer, MDF, and an acoustical core with 56% recycled materials
<b>Thickness</b>	1.25"
<b>Width</b>	Up to 48"
<b>Height</b>	Up to 96"
<b>Tolerance</b>	1/16"
<b>Weight</b>	1.5lbs per sq ft
<b>Edges</b>	Square and Edgebanded or Rounded and Wrapped
<b>Sound Performance</b>	ASTM C423-17 NRC: 0.83
<b>Fire Performance</b>	Class B
<b>Variations</b>	Slight and consistent variations in color and woodgrain should be expected when using this material. Slight imperfections are within normal manufacturing tolerances and not visible in standard installations.
<b>Environmental</b>	Panels consume a quarter of the natural resources and have a dramatically lower carbon footprint compared to equivalent millwork.
<b>Maintenance</b>	Vacuum to remove any loose dirt or dust. A damp cloth or compressed air can also be used to dust the material in difficult or large installations. If stains are present, you may saturate a lint-free cloth with a soap and water solution or Murphy's Oil soap.
<b>Warranty</b>	5 years
<b>Unit of Sale</b>	Per sq. ft.

# Construction & Hardware

## Z-Clip to Z-Clip

- Begin by attaching Z-Clips to panel 6" from edges, using #6 Phillips Bugle Head sheetrock screws. Make sure that the clip faces downward, as shown below in Image 1.
- Attach the bottom Z-Clips to the wall with #8 self-drilling drywall anchors and screws, facing upward—opposite to what is shown below. See Image 2 for diagram.
- Hang your panels! Lift each panel to the wall just above the top row of Z-Clip and gently press the panel into the wall while sliding the panel down into their corresponding Z-Clips.

For panels 20" wide or greater, we recommend you splitting the difference or placing a Z-Clip every 24" horizontally. Do not exceed 24" oc horizontally.

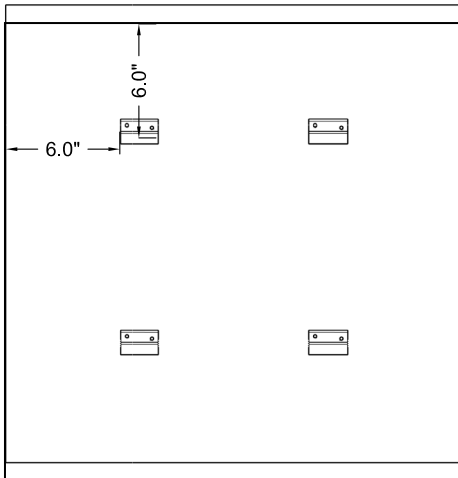

Image 1: Z-Clips placed 6" from edge.

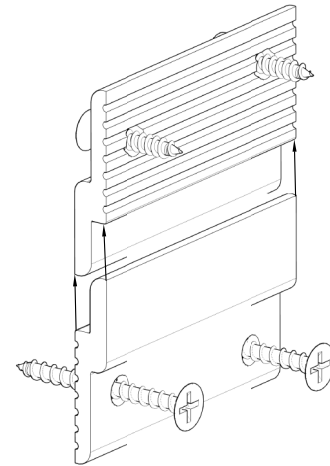

Image 2: Top Z-Clip attaches to panel with #6 screw. Bottom Z-Clip attaches to wall with #8 drywall anchors and screws.

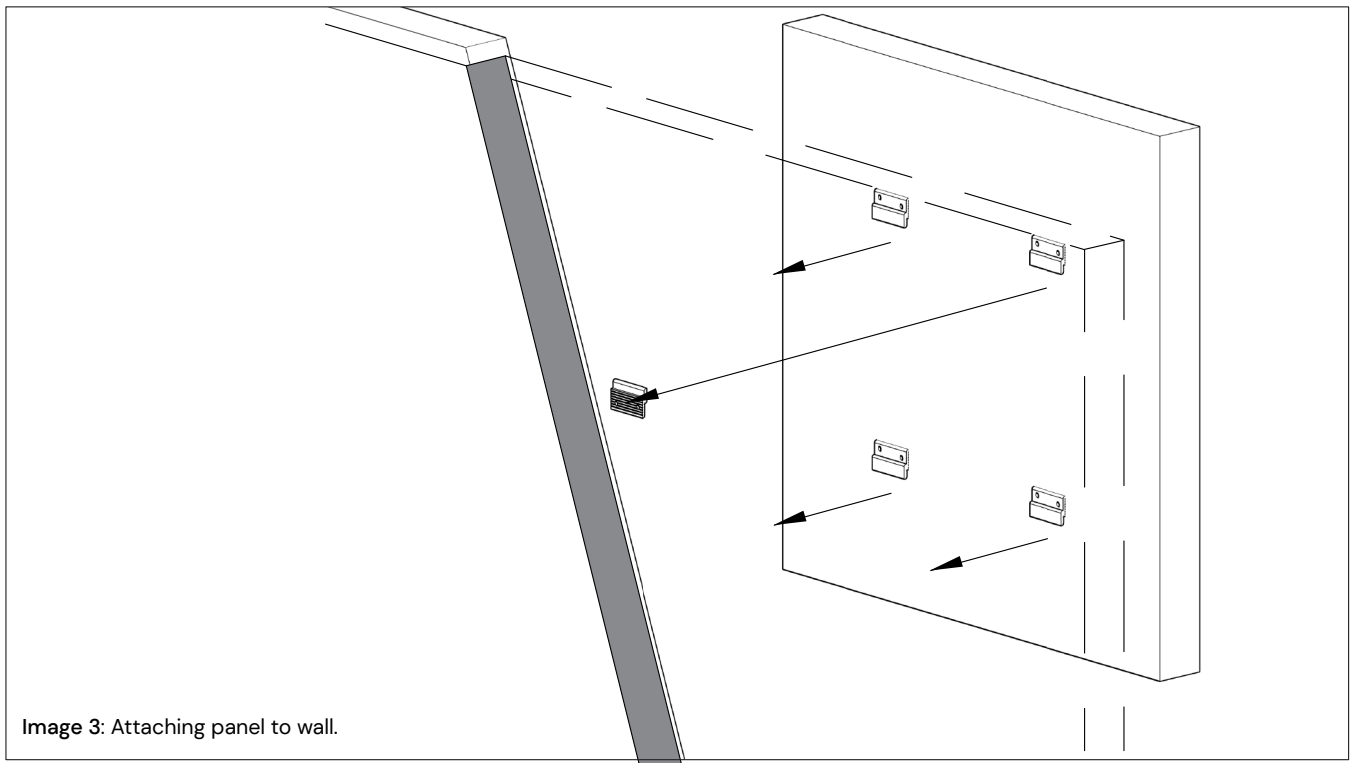

Image 3: Attaching panel to wall.

# Construction & Hardware

## Z-Clip to Z-Bar

- Begin by attaching Z-Clips to panel 6" from edges, using #6 Phillips Bugle Head sheetrock screws. Make sure that the Z-Clip faces downward, as shown in Image 1 and 2.
- Attach Z-Bar to wall at desired height using the selected drilled or undrilled option.
- Hang your panels! Lift each panel to the wall just above the Z-Bar and gently press the panel into the wall while sliding the panel down onto the Z-Bar. See Image 3.

For panels 20" wide or greater, we recommend you splitting the difference or placing a clip every 24" horizontally. Do not exceed 24" oc horizontally.

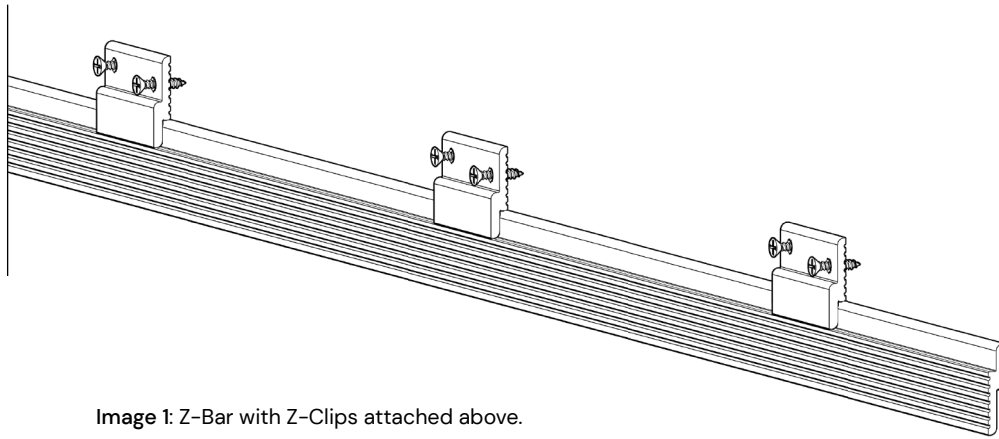

Image 1: Z-Bar with Z-Clips attached above.

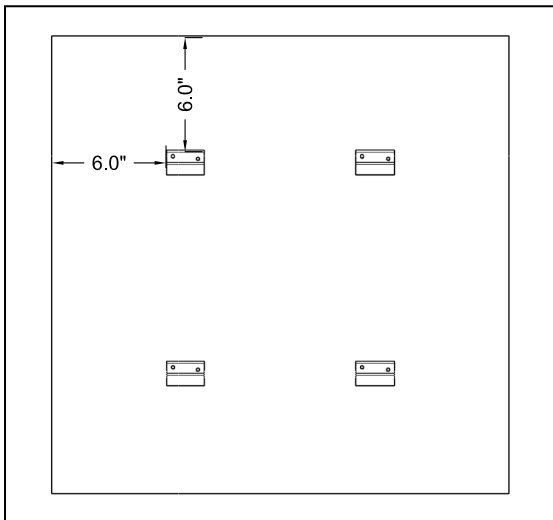

Image 2: Z-Clips on panel are oriented downward to connect with upward facing Z-Bar.

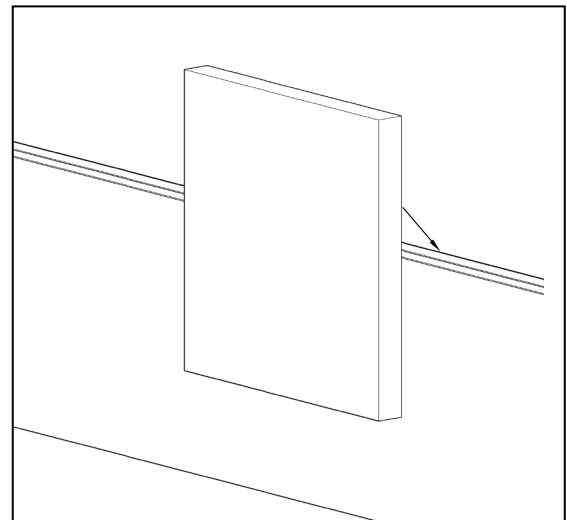

Image 3: Panel attaches to Z-Bar from above.

# Color & Finishes



**One in a Million**

We offer over one hundred veneers, custom staining, and sequencing to meet the needs of any project.



# Test Results

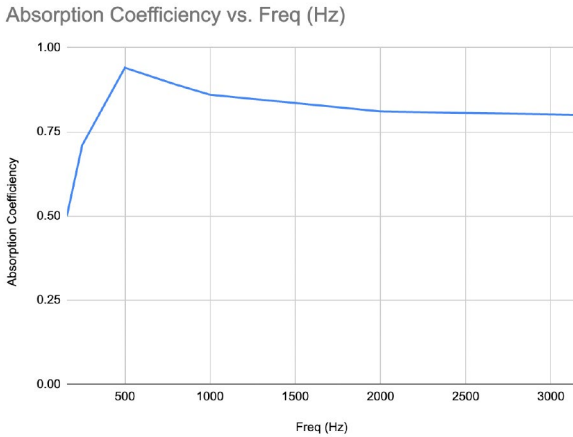

Freq (Hz)	Absorption Coefficient
160	0.50
250	0.71
500	0.94
800	0.89
1000	0.86
2000	0.81
3150	0.80
<b>NRC</b>	<b>0.83</b>

The Noise Reduction Coefficient (NRC) is calculated as the arithmetic average of the absorption coefficients in the shaded bands only (250, 500, 1250 & 2000 Hz).

ASTM C 423-17: Type F Mounting as defined by ASTM E795 using two pieces of 0.5 in aluminum stock bar placed on floor to lift material with trim pieces to simulate a typical wall installation with mounts.